



Gas	Measures	Application
Oxygen	Percent	Process control
Carbon Monoxide		Combustion
Carbon Dioxide		Safety



SENSING TECHNOLOGY

Paramagnetic



Infrared



Key applications

- Physiology studies
- Universities
- Combustion optimization
- Medical gas verification

Portable gas analyzer for measurement of common gas mixtures

Unrivalled performance

- Patented Paramagnetic and Infrared technologies for ultra-sensitive monitoring with complete reliability
- Precision single measurement operation
- Manufactured by Servomex - over 70 years' experience innovating and pioneering gas analysis with thousands of units used in the field every year

Flexible

- Accurate measurement of O₂, CO and CO₂ levels with no background interference
- Internal pump option or AFCD option for pressurised samples
- Ideal for diverse field and light industrial applications including physiology studies, research, combustion optimization, transformer entry, and medical gas verification

Easy to use

- Quick start up and use
- Intuitive, user-friendly interaction and interface
- Long life Li-Ion battery power for maximized uptime
- Ergonomic, small design that is ideal for field use

Low cost of ownership

- Non-depleting technologies maximize availability and reduce maintenance/running costs
- Simplified calibration and ongoing maintenance

Benchmark compliance

- UL approved and CE marked 100-240V / 43-70Hz AC power supply
- CE marked and in compliance with EEC, EMC and WEEE Directives

For more information visit servomex.com/contact

Reliability you can depend on

When you work in light industrial and field applications, you need robust, durable and accurate analytical equipment with immunity to background interference. Your job relies on ultra-sensitive measurements and maximized device uptime – especially when conducting field testing.

No matter what your monitoring requirement, you'll want a device that offers long battery runtime, low operational costs, ongoing maintenance costs and ease of use. And we don't believe you should have to compromise.

A no compromise solution

The MiniHD sets the industry standard for these applications by combining ease of use and simple device care with ultra-sensitive and gas-specific O₂, CO and CO₂ monitoring.

Specifically designed to meet the stringent needs of applications, where performance and accuracy must meet the highest standards, the MiniHD truly delivers on all levels. This device also delivers additional value through its long battery runtime, intuitive and simple interaction and reduced ongoing costs through simplified maintenance.

Life-proof durability

The MiniHD has a highly robust, durable and life-proof design with an IP65 rated case that features protective overmoulding. No matter where your job takes you, the MiniHD is built to last and provide you with many years of reliable gas measurement.

These analyzers are not intended for any form of use on humans and are not medical devices as described in the Medical Devices legislation or regulation.

Please note: Whilst every effort has been made to ensure accuracy, no responsibility can be accepted for errors and omissions. Data may change, as well as legislation, and you are strongly advised to obtain copies of the most recently issued regulations, standards and guidelines. This document is not intended to form the basis of a contract.

Servomex has a policy of constant product improvement and reserves the right to change specifications without notice. © Servomex Group Limited. 2024. A Spectris company. All rights reserved.

Useful links:



servomex.com/service



servomex.com/systems



servomex.com/expert-guidance



Technical data sheet

SERVOFLEX MiniHD 5200



Specifications

Gas measured	Oxygen (O ₂)	Oxygen (O ₂)	Carbon Monoxide (CO)	Carbon Dioxide (CO ₂)
Technology	Paramagnetic	Paramagnetic	Infrared**	Infrared**
Variant	Industrial (1dp)	High accuracy (2dp)	-	-
Full scale range (FSR)	0-100%	0-100%	0-5%	0-10%, 25%, 50%, 100%
Minimum output range	0-10% (min)	0-1% (min)	0-1% (min)	
Cell construction	316 stainless steel	316 stainless steel	316 stainless steel	316 stainless steel
Decimal places	1	2	2	1

** Allow 1 hour warm up to meet performance specification

Performance				
Accuracy	±0.2% O ₂	±0.05% O ₂	±2% FSR	±2% FSR
Zero drift per week	±0.4% O ₂	±0.2% O ₂	±4% FSR	±4% FSR
Response time (T ₉₀)*	<15 seconds	<15 seconds	<10 seconds	<10 seconds
Tilt effect	±0.15% O ₂ (15° from cal)	±0.15% O ₂ (15° from cal)	±1% FSR (15° from cal)	±1% FSR (15° from cal)
Pressure effect	Directly proportional to ambient barometric pressure	Directly proportional to ambient barometric pressure	<0.2% reading / mBar change in ambient pressure	<0.2% reading / mBar change in ambient pressure
Flow variation effect	±0.1% O ₂ change*	±0.1% O ₂ change*	±0.5% FSR change [§]	±0.5% FSR change [§]
Temperature coefficient zero	±0.2% O ₂ per 10°C (18°F) change	±0.2% O ₂ per 10°C (18°F) change	±1% FSR per 10°C (18°F) change	±1% FSR per 10°C (18°F) change*
Temperature coefficient span	±0.3% O ₂ per 10°C (18°F) change	±0.3% O ₂ per 10°C (18°F) change	±5% FSR per 10°C (18°F) change*	±5% FSR per 10°C (18°F) change* (excl 100% CO ₂) ±8.5% FSR per 10°C (18°F) change*, 100% CO ₂ only

Operating environment			
Operating ambient pressure range	101.3kPa abs (1.013 bar abs, 14.7 psi abs) ±10%		
Operating ambient humidity range	0-95% RH, non-condensing		
Operating altitude range	-500 [†] to 5000m [‡] (-1640 [†] to 16,404 [‡] ft)		
Ambient temperature range	Operation	Storage	Battery charging
	-10 to +50°C (+14°F to +122°F)	-20 to +60°C (-4°F to +140°F)	+10 to +40°C (+50°F to +104°F)

- * With internal pump or AFCD version between 1psig (7kPa) and 10psig (70kPa)
- § Across the specified inlet pressure range
- * From +5°C to +45°C (+41°F to +113°F)
The effect of temperature changes occurring between -10°C and +5°C may be greater
- † Below sea level
- ‡ Above sea level

We recommend a calibration of the analyzer after each power up

The performance specification has been written and verified in accordance with the international standard IEC 61207-1:1994 "Expression of performance of gas analyzers"

Sample conditions	
Sample gas	Clean, dry, non-flammable and non-toxic gases only Note: Though samples containing >5% CO ₂ or >200ppm CO are toxic they can be analysed if suitable precautions are taken
Sampling	Internal pump samples at 0.7 litres (0.3 cubic feet) per minute (nominal). User configurable timer
Flow control	To maximise measurement stability, unpumped units are supplied with an automatic flow control device (AFCD), over the specified inlet pressure range this controls sample flow rate to approximately 1.5 to 6 litres (0.05 to 0.2 cubic feet) per minute
Sample inlet connection	5mm OD stub with "QuickConnect" barb fitting for 6.3mm (1/4") ID tube or adaptor to 1/8" NPT fitting (option)
Sample outlet connection	5mm OD stub (sample and bypass)
Inlet pressure	Without pump 7kPa (1 psig) to 70kPa (10psig) With optional internal pump -3.5kPa (-0.5psig) to 3.5kPa (0.5psig)
Sample filter	Replaceable 0.6µm glass fibre particulate filter
Ingress protection	IP65 (protected against dust and low pressure water jets from all directions)
Outer construction	Anti-static, stainless steel loaded polypropylene with carbon filled rubber overmoulding
Physical	
Weight	1.8kgs (4.0lbs) to 2.3kgs (5.1lbs)
Dimensions, WxDxH	W 160mm (6.3") x D 140mm (5.5") x H 185mm (7.3") without protective case W 175mm (6.9") x D 160mm (6.3") x H 195mm (7.7") with protective canvas case
Signal output	
Alarms	Fault alarm and 2 concentration alarms indicated by LED, icon display and audible sounder

Sample wetted materials

	Common gas path	Standard and high accuracy oxygen sensor	Infrared sensor	Optional gas probe	Sample conditioning kit
302 stainless steel	•				
316 stainless steel		•	•	•	•
Borosilicate glass	•	•		•	
Epoxy adhesive			•		
Electroless nickel		•			
Fibre glass					•
Fluorocarbon elastomer (FPM)					•
Gold			•		
Kynar® (PVDF: polyvinylidene fluoride)	•				
Nickel			•	•	•
Nylon				•	
PPS (polyphenylene sulphide) with carbon fibre filler	•				
PPS (polyphenylene sulphide)	•				
Perspex					•
Platinum		•			
Platinum/iridium alloy		•			
Polysulphone	•				
Polyurethane				•	
PVC (polyvinylchloride)				•	•
Sapphire			•		
Silica					•
Viton®	•	•	•	•	•

Options

Description		
Rechargeable batteries	Advanced lithium ion batteries, typical battery life 10 hours at 20°C (68°F)	<input type="checkbox"/>
Additional barb fittings	Additional QuickConnect barb fittings to simplify connection of zero and span gases	<input type="checkbox"/>
1/8" NPT adaptor	QuickConnect fitting to allow connection to hard pipes	<input type="checkbox"/>
Sample conditioning kit	To handle wet or dirty samples	<input type="checkbox"/>
Sampling probes	Stainless steel probes with holder and connecting tube	25cm (9.8") <input type="checkbox"/> 100 cm (39") <input type="checkbox"/>
2 years spares	Recommended spares for two years operation, comprising replacement filters (5) and filter cap 'O' ring	<input type="checkbox"/>
Carry case	Protective canvas case for additional protection	<input type="checkbox"/>
Transport case	Tough plastic shipping case with pre-cut foam insert to hold analyzer and accessories (excl 100cm probe)	<input type="checkbox"/>

Please tick the box for required options

Compliance

EC directives	This product complies with the EMC Directive, the Low Voltage Directive, and all other applicable directives.
Electrical safety	Electrical safety to IEC 61010-1 Rated for "Overvoltage Category II" and "Pollution Degree 2"

Dimensional drawings

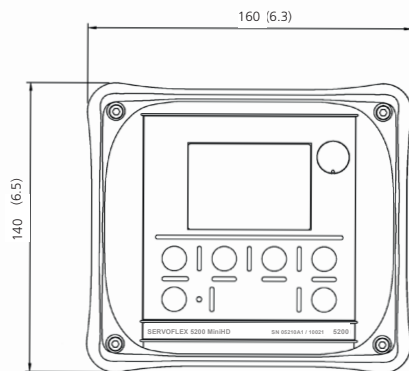

Front

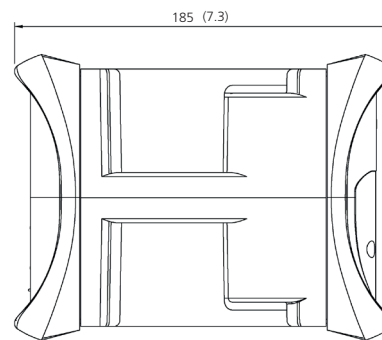

Side

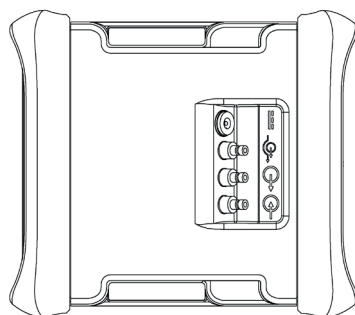

Top

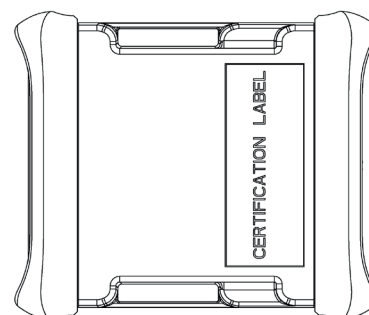

Bottom

Dimensions shown in millimetres
(dimensions in brackets are in inches)

We're ready to help

Whatever your gas
analysis requirements,
wherever you are.

These analyzers are not intended for any form of use on humans and are not medical devices as described in the Medical Devices legislation or regulation.

Please note: Whilst every effort has been made to ensure accuracy, no responsibility can be accepted for errors and omissions. Data may change, as well as legislation, and you are strongly advised to obtain copies of the most recently issued regulations, standards and guidelines.

This document is not intended to form the basis of a contract.

Servomex has a policy of constant product improvement and reserves the right to change specifications without notice.

Analysis that **empowers**

SERVOMEX 
a **spectris** company

© Servomex Group Limited. 2024. A Spectris company.
All rights reserved.

PBTDSMiniHD5200 Rev.1 Date: 10/24